

MS-300
MS-400
MS-800



MS Subwoofer

MISSION

Cautions: Before installing this product read all these instructions.

IMPORTANT SAFETY INSTRUCTIONS



This symbol indicates that there are important operating and maintenance instructions in the literature accompanying this unit.



This symbol indicates that dangerous voltage constituting a risk of electric shock is present within this unit.

WARNING: TO REDUCE THE RISK OF FIRE OR ELECTRIC SHOCK, DO NOT EXPOSE THIS APPARATUS TO RAIN OR MOISTURE.

Read these instructions.

Keep these instructions.

Heed all warnings.

Follow all instructions.

DO NOT use this apparatus near water.

Clean only with dry cloth.

DO NOT install near any heat sources such as radiators, heat registers, stoves, or other apparatus (including amplifiers) that produce heat.

Protect the power cord from being walked on or pinched particularly at plugs, convenience receptacles, and the point where they exit from the apparatus.

Unplug this apparatus during lightning storms or when unused for long periods of time.

Refer all servicing to qualified service personnel. Servicing is required when the apparatus has been damaged in any way, such as power-supply cord or plug is damaged, liquid has been spilled or objects have fallen into the apparatus, the apparatus has been exposed to rain or moisture, does not operate normally, or has been dropped.

Install in accordance with the manufacturer's instructions.

WARNING: If using spikes make sure that they do not pierce mains cable etc. under /above the carpet.

When making any connections, switch the amplifier off.

When you switch on your system or change sources, set the volume control at minimum and turn the level up gradually.

DO NOT use your amplifier at full volume.

Avoid extreme settings of tone controls or graphic equalisers. Ideally, they should be set 'flat' or, if possible, bypassed.

DO NOT place heavy objects on top of loudspeaker cabinets.

Ensure that all loudspeakers in the system are correctly wired and are in phase.

DO NOT connect your loudspeakers to the mains supply, except for subwoofers.

DO NOT attempt to dismantle the loudspeaker. There are no user serviceable

parts inside and you will render the warranty void.

Site hi-fi electronics away from the loudspeakers on a rigid stand or cabinet.

Loudspeakers should not be placed directly facing other hi-fi units, or share the same shelf or cabinet.

Site unscreened speakers and subwoofers at least 0.5m away from TV sets, computers, etc. Some manufacturers forbid the placing of objects on top of their TV sets. Check your TV handbook before installing the centre speaker directly on your TV set. Consult your TV dealer if you are in any doubt.

Use only attachments / accessories specified by the manufacturer.

DO NOT subject loudspeakers to excessive cold, heat, humidity or sunlight.

DO NOT block any ventilation openings.

DO NOT defeat the safety purpose of the polarised or grounding-type plug. A polarised plug has two blades with one wider than the other. A grounding type plug has two blades and a third grounding prong. The wide blade or the third prong are provided for your safety. If the provided plug does not fit into your outlet, consult an electrician for replacement of the obsolete outlet.

The apparatus must not be exposed to dripping or splashing and no objects filled with liquids, such as vases, should be placed on the apparatus.

Use only with a cart, stand, tripod, bracket or table specified by the manufacturer, or sold with the apparatus. When a cart is used, use caution when moving the cart / apparatus combination to avoid injury from tip-over.



CAUTION: The mains power switch for this appliance is located on the rear panel. To permit free access to this switch the apparatus must be located in an open area without any obstructions. The mains power plug must remain freely operable at all times.

CAUTION: Changes or modifications not expressly approved by the manufacturer could void the user's authority to operate this device.

IMPORTANT NOTICE TO UK USERS. The subwoofer is supplied with a plug incorporating a fuse, the value of which is indicated on the pin face of the plug.

If the fuse or plug needs to be replaced refer to the instructions on Page 11.

	CAUTION! RISK OF ELECTRIC SHOCK DO NOT OPEN	
TO REDUCE THE RISK OF ELECTRIC SHOCK DO NOT REMOVE COVER (OR BACK) NO USER-REMOVEABLE PARTS INSIDE REFER SERVICING TO QUALIFIED PERSONNEL		
ADVERTISSEMENT: RISQUE DE CHOC ELECTRIQUE PAS OUVRIRE		



Warning

When an amplifier is driven beyond its power output capabilities it will produce distorted results which will quickly damage your speakers by overheating. Make sure that your amplifier is not left unattended when playing, for example at parties, and turn the volume control down at the first sign of audible distortion.

Warranty Conditions

The warranty card enclosed should be completed and returned to Mission or its Distributor within 8 days of purchase.

No Dealer or Distributor may vary the terms of this warranty which is personal to the original purchaser and is not transferable.

Please retain the sales receipt as proof of purchase.

Warranty claims must wherever possible be made through the Dealer from whom the equipment was purchased.

This warranty excludes:

Damage caused through neglect, accident, misuse, wear and tear, or through incorrect installation, adjustment or repair by unauthorised

personnel. Any unauthorised servicing will result in loss of warranty. Liability for damage or loss occurring in transit to or from the purchaser.

Consequent damage, loss or injury, arising from or in conjunction with this equipment.

Equipment for attention under warranty should be considered return carriage paid. If equipment is found to comply with the published specification, Mission reserves the right to raise a charge.

The above conditions do not affect your statutory rights as a consumer.

Welcome to Mission

The **MS** series is the latest in a long line of distinguished Mission active subwoofers. These technologically advanced subwoofers will complement the finest electronics and decor. Robust bass drivers are used throughout the range.

Screw fastening tri-lobe multi-way binding posts feature on all models. Your Mission **MS** subwoofers will bring you great listening pleasure for many years.

General Information

Please read these instructions carefully before installing your subwoofers. A few minutes studying this manual will ensure superb performance from your subwoofer for many years.

Please pay attention to all cautions printed on the pages marked with this symbol.

Unpacking MS Subwoofers

- Carefully unpack each subwoofer.
- Retain all the packing materials so that your subwoofer can be repacked and shipped without damage.
- If you dispose of the packing, do so with regard to all recycling provisions in your area.

Fitting Spikes



Warning: Be careful. Subwoofer spikes are very sharp. When positioning the speakers avoid piercing any electrical cables.

Fitting the Spikes

- Invert the subwoofer and place the top on a soft stable surface, or place the subwoofers on a towel or soft cloth to protect the surface.
- Screw a nut fully on to each spike but ensure the nut is not tight.
- Screw a spike half way into each thread fitted in the base of the cabinet.
- Tighten the nut finger tight onto the spike retainer.
- Carefully return the loudspeaker to its normal position.
- Ensure that spikes do not pierce cables, etc. under the carpet.

Adjusting the Spikes

- Adjust the height by screwing in or out one or more of the spikes until the loudspeaker is stable and level.
- Tighten the nut fully tight onto the thread.
- For hard floor placement, seat the spikes on rubber feet provided .

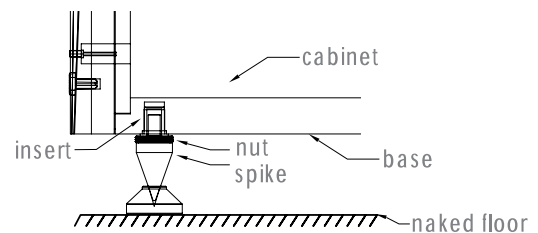
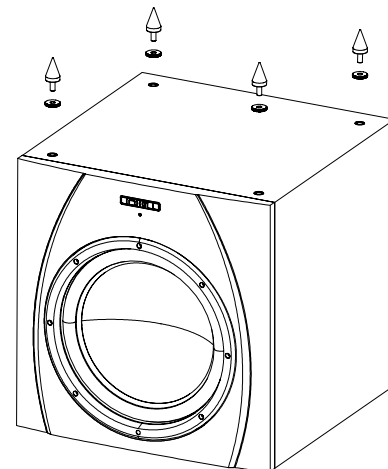

Warning: The **MS-300**, **MS-400** and **MS-800** subwoofers are heavy. Always get someone to help you to lift and manoeuvre the loudspeakers. Never drag a loudspeaker. When moving subwoofers lift them clear of the floor and replace them carefully.

The Mission **MS-300** and **MS-400** Powered Subwoofers

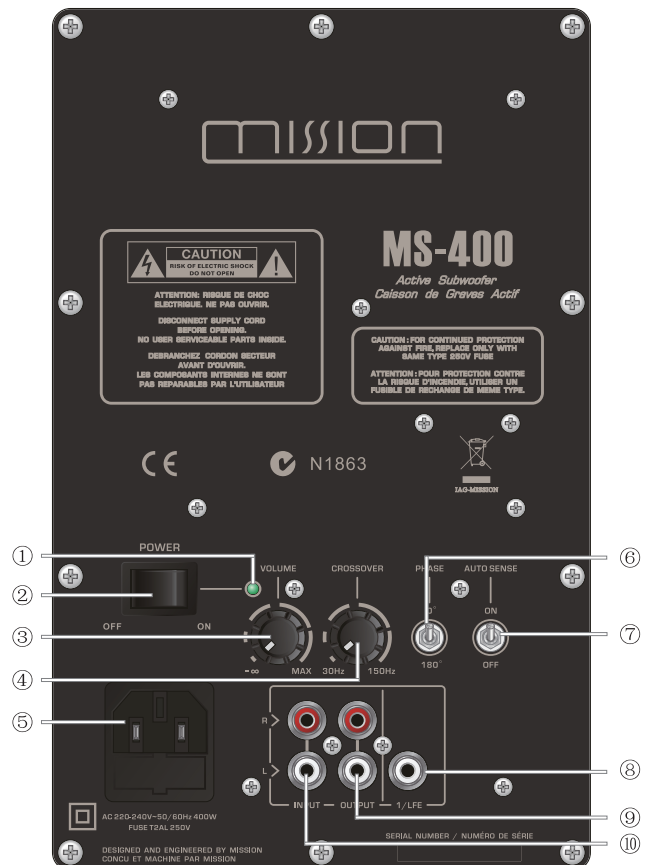
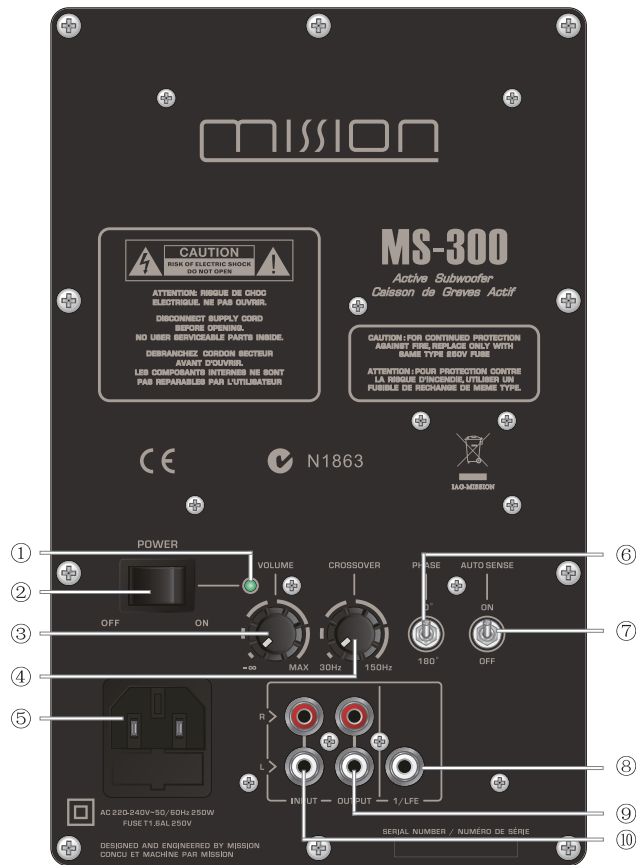

- ① Mains Power Indicator
- ② Mains ON/OFF Switch
- ③ Volume Control
- ④ Crossover Frequency Control
- ⑤ IEC Mains Input Socket

- ⑥ Phase Control
- ⑦ Auto Sense Switch
- ⑧ LFE Input
- ⑨ Line Level High Pass Outputs
- ⑩ Line Level Inputs

Preliminaries

Open the carton and remove all the top packing pieces. Lift the subwoofer out carefully. **DO NOT** lift the subwoofer out of the carton using the protective bag. The unit is heavy; if you cannot manage it easily, get assistance.

Retain the packing materials. If you decide not to keep the packing, please dispose of it having regard to any recycling regulations in your area. Please retain the user manual. If you transfer this equipment to a third party, please ensure all the instructions are passed on with the product.

Power Connections

The subwoofer is factory set to operate from the mains voltage marked on the amplifier panel. Before connecting check this voltage is correct for your mains supply.

If you move to an area with a different mains supply, consult your dealer for advice.

***DO NOT change the operating voltage of this product without seeking expert advice first.**

The Mission **MS-800** Powered Subwoofer



- ① Mains Power Indicator
- ② Mains ON/OFF Switch
- ③ Volume Control
- ④ Crossover Frequency Control
- ⑤ IEC Mains Input Socket
- ⑥ Phase Control
- ⑦ Auto Sense Switch
- ⑧ LFE Input
- ⑨ Line Level High Pass Outputs
- ⑩ Line Level Inputs

Preliminaries

Open the carton and remove all the top packing pieces. Lift the subwoofer out carefully. **DO NOT** lift the subwoofer out of the carton using the protective bag. The unit is heavy; if you cannot manage it easily, get assistance.

Retain the packing materials. If you decide not to keep the packing, please dispose of it having regard to any recycling regulations in your area. Please retain the user manual. If you transfer this equipment to a third party, please ensure all the instructions are passed on with the product.

Power Connections

The subwoofer is factory set to operate from the mains voltage marked on the amplifier panel. Before connecting check this voltage is correct for your mains supply.

If you move to an area with a different mains supply, consult your dealer for advice.

***DO NOT change the operating voltage of this product without seeking expert advice first.**

Positioning Your Subwoofer

Although the unit may be placed almost anywhere in the room, even behind the sofa or the TV set, we recommend that it be placed in front of the listener and as central to the listening position as possible. The subwoofer should not be operated within 450mm of a television set as the drive unit magnet may distort the picture.

We suggest you position the subwoofer about 20cm (8 inches) from the wall. A position close to the wall will enhance the bass; placing it across a room corner will increase the bass further, possibly at the expense of clarity. Experiment with a variety of locations and sources before making a final decision.

The drive unit and bass ports move a lot of air at high volume, so make sure you do not place your subwoofer near surfaces or objects that may rattle.

There should be a mains outlet within easy reach.

Your system will perform best if there is a clear line of sight between the subwoofer and the listening position.

NOTE: When running signal cables to the subwoofer, keep them clear of obstructions. Do not run a long signal cable close to mains cables or cables carrying heavy digital traffic.



Connecting the **MS-300, MS-400, MS-800** Subwoofer

A/V Processor Connections

Your subwoofer has been designed for optimum performance with a Digital processor. If your AV processor has a line level or LFE subwoofer output you should use this connection. You will need to purchase a single screened RCA phono lead from your dealer. Connect this lead to the LFE input of the subwoofer as shown.

Alternatively, you may use a split mono lead from the processor to both inputs of the subwoofer. In this case the input level at the subwoofer will be slightly higher.

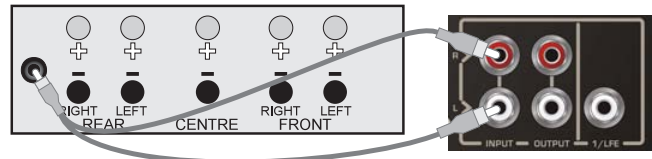
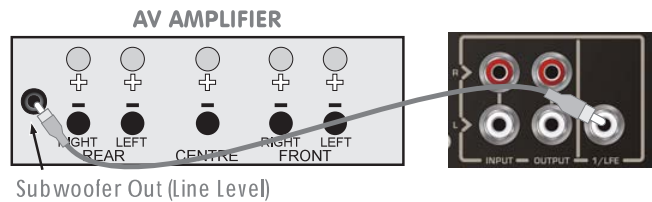

Stereo Line Output Connections

If your amplifier has a spare preamplifier output or a stereo subwoofer output, connect the subwoofer as shown. You will need a stereo screened RCA phono cable.

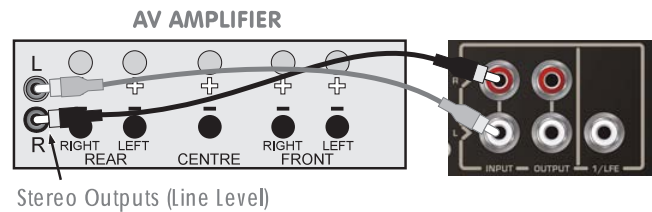

Pre Out - Main In Connections

If you use a stereo pre and power amplifier, or an amplifier where the pre and main amplifier can be separated, connect the subwoofer as shown. There are two alternative methods.

You will need two screened RCA 'Y' adaptors and two single RCA phono cables.

Remove the Pre-Main links on your amplifier. Connect the socket (common) of an RCA 'Y' adaptor to one of the mono cables. Connect one leg of the 'Y' adaptor to the Left Channel Pre Out socket on the amplifier and the other leg to the Left Channel Main In socket. Connect the remaining plug on this combination to the Left Channel Line Level Input on the subwoofer. Repeat this for the Right Channel.

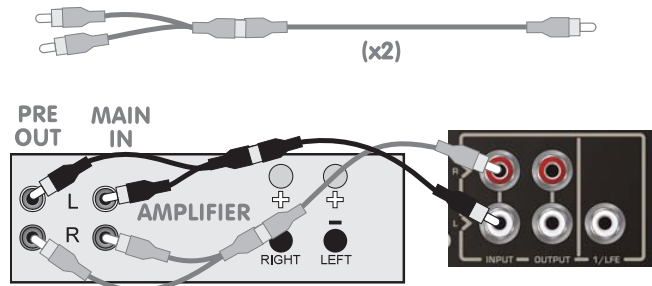

Pre-Amp and Power Amp Connections

You will need two stereo (or four single) screened RCA cables.

Connect a stereo cable from the Line Level Inputs of the subwoofer to the Output sockets of the pre-amplifier. Now connect a second stereo cable from the Line Level (High pass) Outputs of the subwoofer to the input sockets of the power amplifier. Make sure that the Right and Left Channels are not mixed up! The built-in high pass filter will roll off the low frequency output to the power amplifier and subsequently the main speakers.

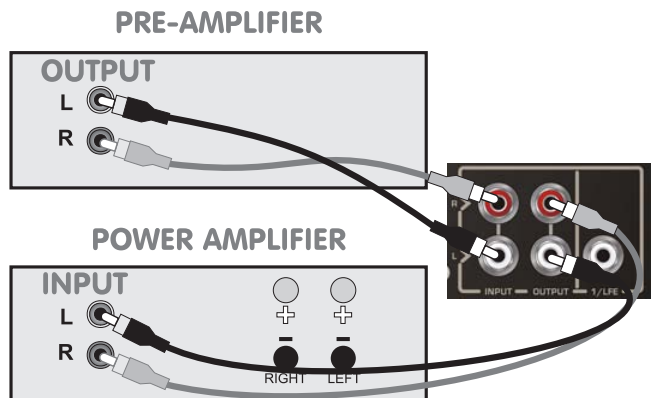

Setting Up Your Subwoofer - All Models

- Set the subwoofer power switch to OFF.
- Turn the system volume control to minimum.
- Re-check all system connections.
- Connect the supplied power lead to the IEC power socket on the subwoofer and connect the mains plug into the wall socket.
- Set the subwoofer volume control midway (12 o'clock).
- Switch on the mains power.

Fine Tuning Your Subwoofer

Switch on the subwoofer power switch. Check that the power indicator on the amplifier panel glows. Now switch on the system. Play a programme with extended bass and set the system volume to a reasonable level. Adjust the subwoofer volume control to produce the desired level of bass.

PHASE SWITCH: If the bass is indistinct or lacks depth, the Phase switch may need adjustment. Set the switch to 0° and listen carefully to some music with extended bass. If there is insufficient bass output from the subwoofer set the Phase switch to 180°. Select the position which produces the most natural, extended bass.

LOW PASS (CROSSOVER) FILTER: This adjusts the blend between the subwoofer and the main speakers, and enables the system to be set up for optimum bass performance. The higher settings are for use with bookshelf loudspeakers, the lower settings for large floorstanding models. If you choose too low a setting with small speakers, there will be a 'hole' in the bass response; too high a setting with large speakers will result in the upper bass becoming bloated.

AUTO SENSE SWITCH: In normal mode the subwoofer is permanently on. This may result in low level hum or noise if the rest of the system is switched off and the subwoofer is left switched on.

When the system is not in use for extended periods, we suggest you switch off the subwoofer to protect it from switching noises.

LOUDSPEAKER SIZES: Many digital AV processors require you to specify the size of speakers in the various channels. These are usually 'Large' or 'Small'. We recommend that you set the centre and surround speakers to 'Small'. This will direct all the bass in the system to the subwoofer and provide clean, deep and louder bass. Set the 'Subwoofer' option on the processor to 'On' or 'Yes'.

Subwoofer Settings for Front Loudspeakers

Set large floorstanding loudspeakers to 'Large' and the subwoofer setting to 55Hz. Smaller floorstanding loudspeakers may be optionally set to 'Small'. In this case the subwoofer crossover setting should be 85Hz. If you find the bass excessive, set the loudspeaker to 'Large' and resume the 55Hz crossover setting.

Set bookshelf and stand mounted loudspeakers to 'Small'. If you are using a digital AV processor the subwoofer crossover setting should be 85Hz.



SETTING LEVELS: (Read this together with your processor instructions.) Once the loudspeaker settings have been finalised, put the AV amplifier into its 'Test' mode. Adjust the levels until all channels are equally loud. You may need to adjust the subwoofer output level. Avoid setting too high a level which may limit the subwoofer's ability to respond to large bass transients. Set a sensible level going into the subwoofer. The subwoofer volume control should be between 12 o'clock and 3 o'clock.

LFE: If all the speakers are set to 'Small', the LFE channel will be combined with the bass from other channels and all this feeds into the subwoofer. When you set the LFE level from your AV processor, use care as the LFE channel may contain powerful low frequencies which may overload a domestic subwoofer. If, during a programme, you hear popping or thumping noises coming from the subwoofer, immediately turn the AV processor's volume level down and then back off the LFE level. If this does not cure the problem, back off the volume level at the subwoofer.

Stereo Reproduction

Low Pass Filter

The subwoofer crossover point should be set having regard to the size and low frequency extension of the main speakers. The role of the subwoofer is to extend the bass response of the system, not to increase the overall bass level. If the loudspeakers are large the crossover should be set low, a value around 55Hz is a good place to start. With smaller speakers this can be increased, up to 85Hz for the small bookshelf units. As always the final value is determined by listening.

Low-level Listening

Our ears are far more sensitive to midrange frequencies (2-5 kHz) than bass frequencies. Very low bass and especially percussive bass is 'felt' rather than heard. At low sound levels bass frequencies appear to attenuate faster than midrange and treble. As the level increases this bass roll-off decreases. Occasionally we may wish to listen to a normally loud piece of music at a low level but with retention of the bass information.

Testing the System

The simplest way to test the system is to play, at a moderate level, music with deep consistent bass. Switching the subwoofer on and off should cause change of the depth of bass, and the ambience will also alter. If there is a significant change in bass volume, or a noticeable step in the bass response, or an increase in colouration when the subwoofer is playing, the setup needs to be refined. By selecting different crossover and volume settings, you will be able readily to identify the most favourable combination.

Dolby Labs Recommended 7.1 Placement

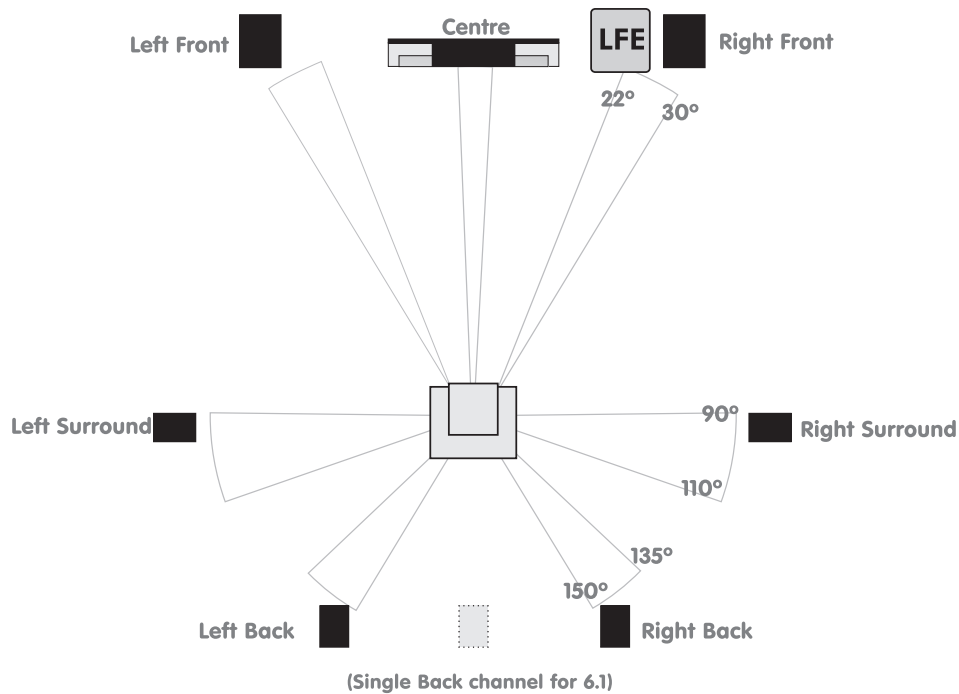

Troubleshooting

Before investigating a problem, always switch off the system at the mains.

If your system is not working properly please work through this checklist before returning a unit to your dealer.

Symptom	Possible Cause
No Sound	System not switched on; Speaker cables shorting terminals out; Wrong source selected
Sound lacks bass content	Subwoofer not switched on
Bass reproduction indistinct	Subwoofer phase incorrect; Subwoofer crossover control too low
Excessive bass distortion at low volume	Subwoofer level set too high; LFE level set too high; Subwoofer incorrectly wired
Excessive or distorted bass at high levels	System level set too high; Bass control set too high; Subwoofer too close to room corners
Distorted / rattling sounds at high levels	System level set too high; Objects on subwoofer; Objects too close to subwoofer
Popping or thumping from the subwoofer	System level set too high; Subwoofer level set too high; LFE level set too high
Television picture colour is distorted	Subwoofer too close to TV. (Switch off system and TV. Move units away. Leave 15 mins. Switch on.)

Subwoofer Maintenance

Subwoofers should only ever be cleaned with a soft dry cloth to remove fingermarks, etc.

Never touch subwoofer drive units as they can be damaged by improper handling.

Never use a vacuum cleaner to clean a subwoofer grille. Brush it carefully by hand with a soft brush.

When cleaning the floor under a subwoofer, switch it off, unplug it from the mains supply then lift it clear of the floor and move it to another location. Replace the subwoofer after cleaning.

Product Service

Should a fault occur with your subwoofer, please pack it correctly, using the original packing, so you can ship it safely.

Product for service should be returned to the appointed dealer from whom you purchased the product. If you experience difficulties or there is no Mission dealer in your area, contact the Mission distributor for your country or the Main Service Centre for your region.

Authorised Service Centre

UK

International Audio Group
Unit 4, St Margaret's Way
Stukeley Meadows Industrial Estate
Huntingdon, Cambs, PE29 6EB
Tel: +44 (0)1480 447700 Fax: +44 (0)1480 431767

Specifications

	MS-300	MS-400	MS-800
Description/Format	Active Dynamic-Drive IB subwoofer system		
Drive Units	1 x 200mm (8") cone long-throw	1 x 250mm (10") cone long-throw	1 x 300mm (12") cone long-throw
Frequency Response	40 - 120Hz \pm 3dB	35 - 120Hz \pm 3dB	30 - 120Hz \pm 3dB
Amplifier Power Output	150W	215W	400W
Peak Power Output	330W	450W	850W
Line Input Sensitivity	200mv for maximum output	200mv for maximum output	200mv for maximum output
Crossover Range	30 - 150Hz	30 - 150Hz	30 - 150Hz
Inputs	Stereo Line In (2 x RCA)	Stereo Line In (2 x RCA)	Stereo Line In (2 x RCA)
	Mono (LFE) Line In (RCA)	Mono (LFE) Line In (RCA)	Mono (LFE) Line In (RCA)
Input Impedance	Line In 10k Ω	Line In 10k Ω	Line In 10k Ω
	LFE 5k Ω	LFE 5k Ω	LFE 5k Ω
Output	Stereo High Pass Line Out (2 x RCA)		
Signal-to-noise ratio (S/N)	\geq 85dB	\geq 85dB	\geq 85dB
Avg. Max Output @1m	110dB	115dB	117dB
Features	Phase inversion, Auto on-off	Phase inversion, Auto on-off	Phase inversion, Auto on-off
Dimensions(HxWxD)mm	341 x 296 x 325	402 x 352 x 375	447 x 400 x 425
Net weight	9.4kg	14.6kg	17.2kg
Accessories	IEC power cord, spikes as standard		

Mission reserves the right to change all specifications without notice. E & OE

Note for UK Customers

The power cord on your subwoofer may be supplied with a plug incorporating a fuse, the value of which is indicated on the pin face of the plug. Should the fuse need to be replaced, an ASTA or BSI approved BS1362 fuse must be used of the same rating. If the plug is cut off it must NOT be re-used. Dispose of any such plug safely. There is a danger of electric shock if a cut-off plug is inserted into a mains socket.

The wires in the mains lead are coloured in accordance with the following code: Green and Yellow - Earth; Blue - Neutral; Brown - Live.

As the colours of the wires in the mains lead may not correspond with the markings identifying the terminals in the replacement mains plug, proceed as follows:

The wire coloured Blue must be connected to the terminal marked with the letter 'N' or coloured Black.
The wire coloured Brown must be connected to the terminal marked with the letter 'L' or coloured Red.

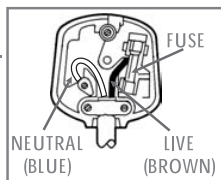

Class II construction double insulated.
This product must not be connected to earth.



MISSION

IAG House, Sovereign Court, Ermine Business Park, Huntingdon, Cambs, PE29 6XU, UK
Tel: +44(0)1480 447700 Fax: +44(0)1480 431767 <http://www.mission.co.uk>
IAG reserves the right to alter the design and specifications without notice. All rights reserved © IAG Group Ltd.
Mission is a member of the International Audio Group. CODE: MH11-MNL0003